

# POULAN S-200 SPECIFICATIONS

TYPE OF ENGINE	Single cylinder, two stroke per cycle and aircooled.
WEIGHT	12 pounds
TYPE OF CYLINDER	Die cast, deep finned aluminum alloy. High nickel chrome alloy cylinder liner, corrosion, wear and friction resistant. Loop scavenging.
BORE	2½ inches
STROKE	1½ inches
DISPLACEMENT	5.8 cubic inches
IGNITION	Moisture and dust proof, built-in flywheel magneto for faster starting. Enclosed ignition points and rugged ground switch direct to magneto for safe, positive on-off.
BREAKER POINT GAP (inches)	.020
SPARK PLUG TYPE	Poulan 10-C
SPARK PLUG GAP (inches)	.022-.025
CARBURETOR TYPE	Diaphragm type. Enables engine to operate efficiently in all positions. Adjustable for idle speed mixture and for high speed mixture.
TYPE FUEL RECOMMENDED	Automotive, regular grade.
FUEL-OIL MIXTURE WITH POULAN OIL	One quart of oil to <sup>1 WC</sup> 16 gallons of gasoline.
FUEL TANK	Conventional types adaptable.
TYPE CRANKCASE VALVE	Oversize reed.
CRANKCASE MATERIAL	Thick, strong aluminum alloy castings.
CRANKSHAFT MATERIAL	Drop forged, SAE 8620 steel carburized, hardened and ground.

CONNECTING ROD MATERIAL	Drop forged, SAE 8620 steel, hardened, ground, and broken by special process to insure perfect fit with no distortion to rod or cap.
CONNECTING ROD LENGTH CENTER TO CENTER (IN.)	2.812
CONNECTING ROD CRANKPIN BEARINGS	14 caged rollers.
CONNECTING ROD WRIST PIN BEARING	Needle bearing.
MAIN BEARINGS	Ball and roller bearing.
PISTON	Special aluminum alloy.
NUMBER AND TYPE PISTON RINGS	3 narrow compression rings assuring quick sealing, low friction and long life. Top ring Chrome plated.
ROTATION	ENGINES ARE ASSEMBLED (on order) to drive Kart in a clockwise or counter clockwise direction. Engine can be changed to rotate in opposite direction to factory assembly and back again with basic tools within a few minutes.

## OPTIONAL EQUIPMENT

MUFFLER	Semi-tuned
AIR FILTER	Conventional type
MOUNTING PLATE	Design adaptable to either right- or left-hand drive.
CLUTCH	Automatic centrifugal
STARTER	Automatic re-wind

Poulan Chain Saws, one of the oldest manufacturers of chain saw engines, now gives you maximum dependability and speed in the finest kart engine you can buy — the POULAN S-200! Designed to give you power-peaked performance hour after hour, race after race.

## POULAN S-200 MOUNTING DATA

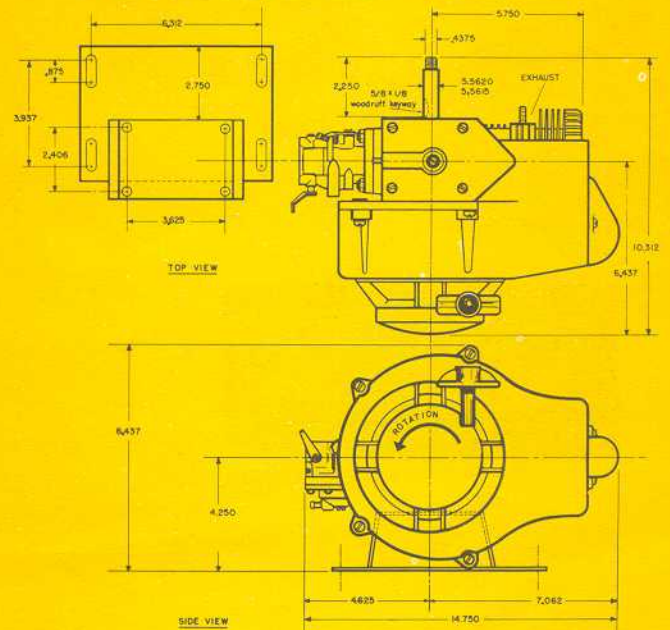

SUBSIDIARY OF BEAIRD-POULAN INC.

P. O. BOX 9066 • SHREVEPORT, LOUISIANA